

INDUSTRIAL CRANES
NUCLEAR CRANES
PORT CRANES
HEAVY-DUTY LIFT TRUCKS
SERVICE
MACHINE TOOL SERVICE

KONECRANES®
Lifting Businesses™

NOT JUST A CRANE UNITON



JUST THE PERFORMANCE YOU NEED

UNITON

UNITON, a crane with a built-up trolley, is the product of Konecranes' vast experience of heavy-duty industrial processes. UNITON will fulfill your load handling requirements and provide much more: Konecranes quality and reliability with every lift.

UNITON is an excellent all-around crane with good fundamentals and performance. It provides the duty class, hoisting speeds and trolley traversing speeds you need and full compliance with your safety requirements.

Your assurance of reliable performance and long life is the Konecranes Core of Lifting, the package of motor/gearbox/control system that we design ourselves and manufacture in-house or in close cooperation with key partners.



BUILD UP YOUR TROLLEY AND CRANE

MECHANICAL CONFIGURATIONS

Multiple trolley configurations available:

- Two hoists on one trolley
- Two hooks on one hoist
- Drum parallel with main girders

Hoisting machinery:

- Drum and gearbox built to account for rope drum deflections
- Compact hook block for increased hook height
- Hook safety latch to keep fingers from the hook opening

MAXIMIZE SPEED CONTROL

Hoist, trolley and bridge speeds can be tailored to your performance requirements. Plus, Extended Speed Range (ESR) helps you achieve your required performance with minimized peak power and energy consumption.

LOAD CONTROL FEATURES

Standard:

- Shock Load Prevention
- Slack Load Prevention (with a lifting device)

Optional:

- Sway Control
- Inching
- Microspeed
- Load Floating
- Hoist Synchronization
- Tandem Drive (between 2 cranes)

TRUCONNECT REMOTE MONITORING

AND REPORTING: for improved maintenance and reliability

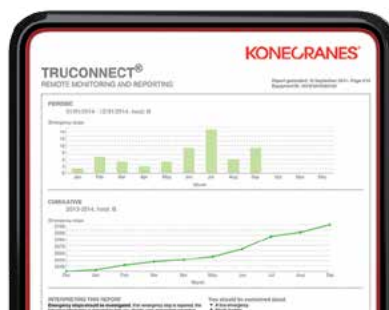

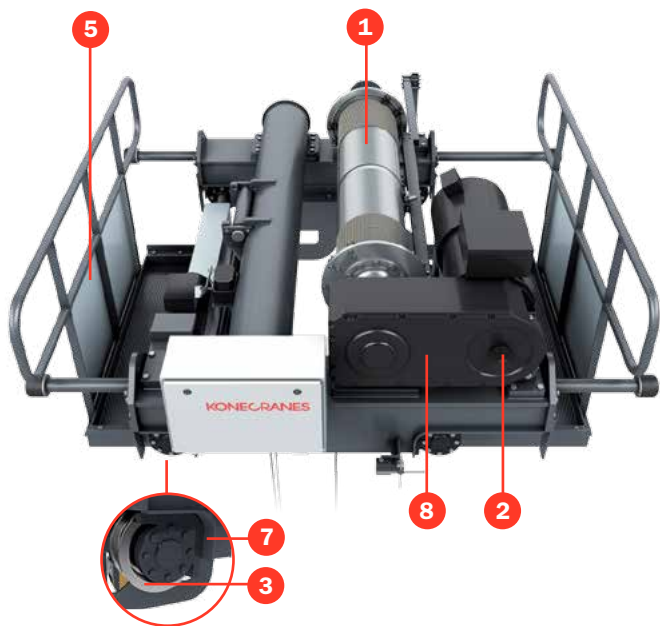

TECHNOLOGY HIGHLIGHTS

- 1 Deep drum grooves available for heavy-duty use
- 2 Second hoist brake available for improved safety
- 3 Hardened steel wheels available for heavy-duty applications
- 4 Several rope reeving options for each rated load/duty class combination
- 5 Service platform available for easy and safe maintenance access.
- 6 Trolley rail gauge is designed for the required lifting height; minimized buffer-to-buffer dimension; maximized lifting space
- 7 Easy-to-replace 90 degree MCB-type bearing housings and wheels, both trolley and bridge end carriages
- 8 Gear reducers custom-built for crane use. Hardened and ground gearing to meet the highest requirements in the industry.
- 9 Latch trigger

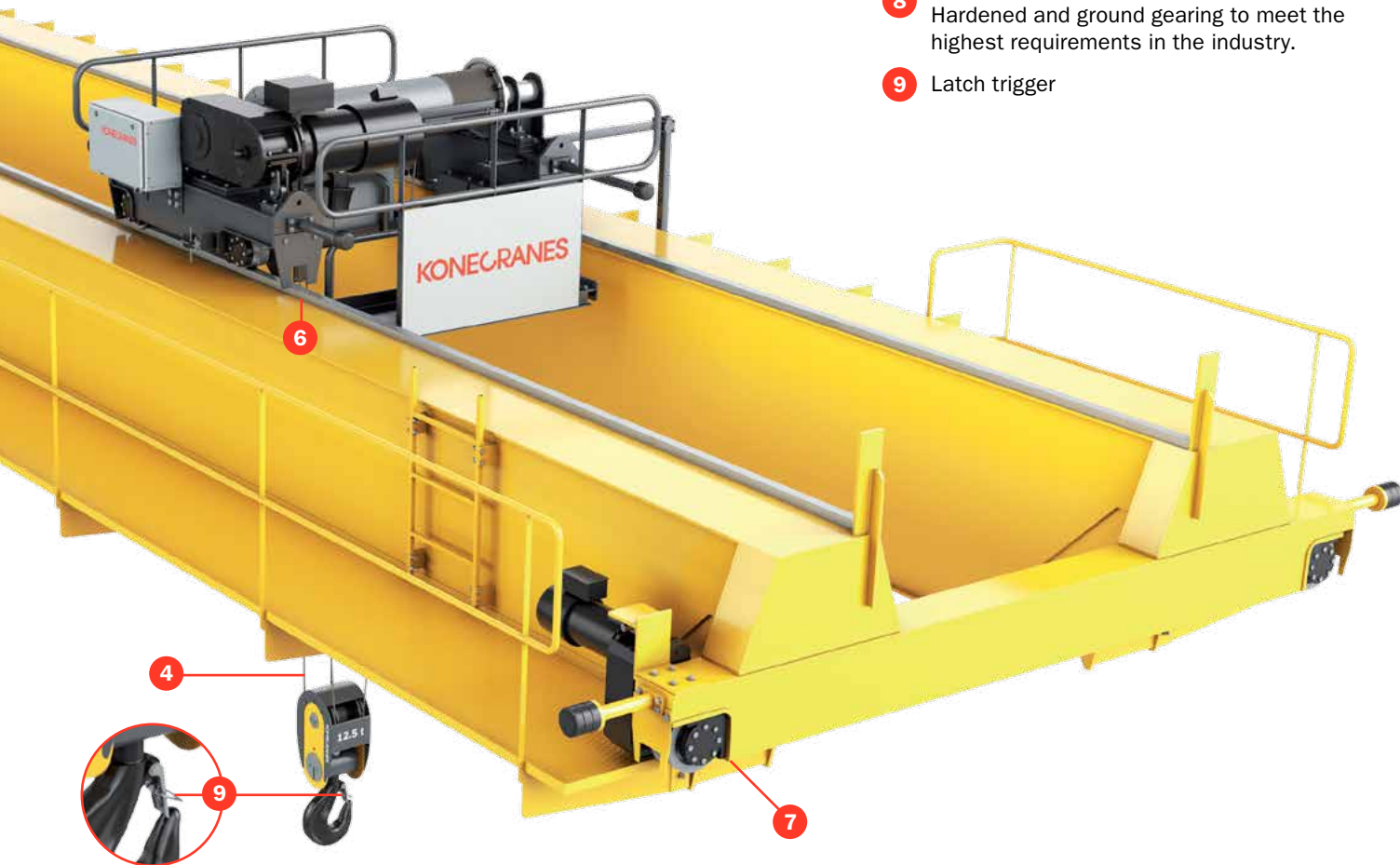



Konecranes is a world-leading group of Lifting Businesses™ offering lifting equipment and services that improve productivity in a wide variety of industries. The company is listed on Nasdaq Helsinki Ltd (symbol: KCR1V). With approximately 12,000 employees at 600 locations in nearly 50 countries we have the resources, technology and determination to deliver on the promise of Lifting Businesses™.

© 2015 Konecranes Plc. All rights reserved. 'Konecranes', 'Lifting Businesses', , 'UNITON' and "TRUCONNECT" are either registered trademarks or trademarks of Konecranes Plc.

UNITON HOISTING SPEEDS
Maximum speeds (m/min) with rated load (400 V, 50 Hz)

RATED LOAD (TONS)	M3	M4	M5	M6	M7	M8
160	1.5	1.5	1.5	1.5		
125	1.5, 2	1.5, 2	1.5, 2	1.5, 2		
100	1.5, 2	1.5, 2	1.5, 2	1.5, 2		
80	3, 4, 6	3, 4, 6	3, 4, 6	3, 4, 6		
63	3, 4, 6	3, 4, 6	3, 4, 6	4, 8	8	8
50	4, 8, 12	4, 8, 12	4, 8, 12	4, 8, 12	8	8
40	4, 8, 12	4, 8, 12	4, 8, 12	4, 8, 12, 15	8, 12, 15	8, 12, 15
32	4, 8, 12	4, 8, 12	4, 8, 12	4, 8, 12, 18	8, 12, 18	8, 12, 18
25	4, 8, 12	4, 8, 12	4, 8, 12	4, 8, 12, 24	8, 12, 24	8, 12, 24
20	4, 8, 12	4, 8, 12	4, 8, 12	4, 8, 12, 24	8, 12, 24	8, 12, 24
16	4, 8, 12	4, 8, 12	4, 8, 12	4, 8, 12, 24	8, 12, 24	8, 12, 24
12.5	4, 8, 12	4, 8, 12	4, 8, 12	4, 8, 12, 24	8, 12, 24	8, 12, 24
10				4, 8, 12, 24	8, 12, 24	8, 12, 24
8				4, 8, 12, 24	8, 12, 24	8, 12, 24
6.3				4, 8, 12, 24	8, 12, 24	8, 12, 24

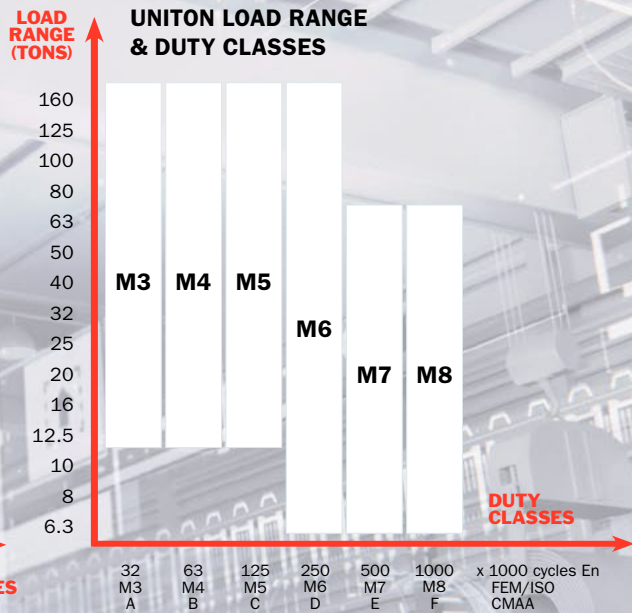

Standard trolley traverse speeds up to 61 m/min